



Byron Shire

Development Control Plan 2014

Chapter B4

Traffic Planning, Vehicle Parking,
Circulation and Access



**BYRON
SHIRE
COUNCIL**

Contents

B4.1	Introduction	4
B4.1.1	Purpose of this Chapter	4
B4.1.2	Aims of this Chapter.....	4
B4.1.3	Application of this Chapter	4
B4.1.4	Relevant Byron LEP 2014 Provisions	4
B4.1.5	Road Access and Safety Principles	4
B4.2	Development Controls	5
B4.2.1	Traffic Impact	5
B4.2.2	Parking Layout Standards.....	7
B4.2.3	Vehicle Access and Manoeuvring Areas	8
B4.2.4	Structures Adjacent to Driveways	9
B4.2.5	Car Parking Requirements.....	9
B4.2.6	Underground/ Basement Car Parks.....	10
B4.2.7	Car Parking Credits and Street Parking.....	10
B4.2.8	Bicycle, Motorcycles and Coach Parking.....	11
B4.2.9	Loading Bays	12
B4.2.10	Monetary Contributions.....	12
B4.2.11	Landscaping.....	13
B4.2.12	Parking Schedules	15

Tables

Table B4.1 – Parking Rates.....	15
Table B4.2 – Loading Bays.....	22

Figures

Figure B4.1 – Minimum Sight Lines for Pedestrian Safety	9
Figure B4.2 – Car park landscaping configurations.....	14

Adopted: DRAFT

Effective: DRAFT

Document History

Doc No.	Date Amended	Details (e.g. Resolution No.)
#E2014/4306	20 March 2014	Res 14-118 – Public exhibition version
#E2014/32417		Draft to 26 June 2014 Extraordinary Meeting - for adoption
#E2014/42597	26 June 2014	Adopted Version – Res 14-315
#E2018/26218	22 March 2018	Adopted 22 March 2018 Effective 12 April 2018 – Res 18-130 'Housekeeping' amendment (various chapters).
#E2019/31383	April 2019	Public exhibition version – Revision 2 (Res 19-091)
#E2019/31383	July 2019	Minor amendments for adoption at 15 August planning meeting
E2019/65598	15 August 2019	Adopted 15 August 2019 Effective 11 September 2019 – Res 19-374
E2022/87905	October 2022	Draft - pdf attachment to Council meeting 13/10/2022 DCP 2014 Amendments 2022, amendments in red text
E2022/52488	October 2022	Res 22-554 Public Exhibition and Adopted version
E2022/52488	January 2023	Adopted 5 December 2022, Effective 25 January 2023 Res 22-554, DCP 2014 Amendments 2022
E2024/104523		Draft for Public exhibition, Res 24-373

B4.1 Introduction

B4.1.1 Purpose of this Chapter

The purpose of this Chapter is to provide guidelines, controls and standards for traffic planning, vehicle access, circulation and parking for developments.

B4.1.2 Aims of this Chapter

The Aims of this Chapter are to:

1. To ensure that all relevant traffic impacts relating to development are identified, assessed and mitigated.
2. To ensure that parking supply and management in new developments supports Council policies and objectives for the development of Byron Shire;
3. To ensure that traffic generating developments make adequate provision for off-street car parking, such that the needs of occupants, users, visitors, employees, service and delivery vehicles are met;
4. To ensure the safe and efficient circulation of vehicles entering, leaving and within car parking and service/delivery areas;
5. To minimise the detrimental effects (particularly visual and radiated heat effects) associated with off-street car parking areas on the amenity of urban areas
6. To ensure that entry/exit points to car parking and service/delivery areas are situated in a way that sight distances are maximised, and disruption to the circulation of vehicles on the public road system is minimised.
7. To have regard to the objectives contained within the Byron Shire Strategic Transport Statement (Transport Policy)

B4.1.3 Application of this Chapter

This Chapter applies to all development types where vehicle access and/or parking is required.

B4.1.4 Relevant Byron LEP 2014 Provisions

There are no specific LEP provisions relating to car parking and vehicle access other than Clause 6.6 which requires the provisions of suitable vehicular access for developments. A **car park** has the same meaning as defined under Byron LEP 2014. Land uses in Table B4.1 have the same meaning as defined under Byron LEP 2014.

B4.1.5 Road Access and Safety Principles

The following principles are to be considered for applications that propose access to public roads or where an upgrade or alteration to a public road is required.

Adopted: DRAFT

Effective: DRAFT

1. All users and modes of transport have an equal right of safe access to and movement on the road network.
2. Road safety audits must consider the access and safety of all road users, modes of transport and services delivered within the road reserve such as bus stops and waste collection.
3. Road upgrades must demonstrate that works have considered all road users, modes of transport and services delivered in the road reserve.
4. New roads must include safe access infrastructure for cyclists, pedestrians and services delivered in the road reserve.

B4.2 Development Controls

B4.2.1 Traffic Impact

1. Introduction

A traffic impact assessment is a process of compiling and analysing information on the impacts that a specific development proposal is likely to have on the operation of roads and transport networks.

The assessment will not only include general impacts relating to traffic management (road efficiency and safety), but should consider specific impacts on all road users, including on-road public transport, pedestrians, cyclists and heavy vehicles.

The scope of a traffic impact assessment will depend on the location, type and size of the development and the ability of the road network to handle traffic generated by the development. The assessment may have to address broader transport planning and environmental considerations and will need to take into account any traffic management strategy, strategic plan or local development plan. All traffic impact assessments must address the Road Access and Safety Principles described above.

A traffic impact assessment is undertaken by competent experts on behalf of the proponent of a development and is documented in a *Traffic Impact Statement* or *Traffic Impact Study*, according to level of impact.

2. The Need for Traffic Impact Assessment

The traffic attracted to a new land use development or a major expansion of an existing development, such as an industrial project or a major shopping centre, can have significant impacts on the performance of the current or future road network. These need to be properly assessed and addressed so that a satisfactory level of road safety and transport efficiency is maintained.

Judgment is required to decide whether a project requires a full traffic impact assessment or some lesser analysis of traffic issues. For example, small urban developments may only require alterations to driveways and off-street parking spaces, whereas a similar development on a rural road may require turn lanes because of the high speed environment, the level of traffic generated and/or site geometry that restricts visibility.

Adopted: DRAFT

Effective: DRAFT

The following is a guide for deciding on the level of traffic assessment required:

- a) Low Impact (generally less than 10 peak hour trips) – submit a safety assessment demonstrating satisfactory access location, sight distances and sightlines to pedestrians.
- b) Moderate Impact (10 – 50 peak hour trips) – *Traffic Impact Statement* required.
- c) High Impact (more than 50 peak hour trips) – *Traffic Impact Study* required.

The need for a traffic impact assessment can be influenced by many factors apart from the volume of peak hour traffic to be generated by the development. Where other criteria are significant, the discretion of Council can be exercised. Where development is to be located in a particularly sensitive area (e.g. densely populated) a traffic impact study may be deemed necessary, even though fewer than 10 peak hour trips are generated. Conversely, there may be cases where the development is in an isolated and less sensitive area and a traffic impact statement is considered to be sufficient even though the development generates more than 50 peak hour trips. Similarly a lower threshold, in terms of additional traffic generated, may be appropriate in more densely populated areas.

3. Traffic Impact Statement

A *Traffic Impact Statement* serves the same purpose as a traffic impact study but is not as comprehensive. A *Traffic Impact Statement* should include:

- a) a brief description of the development in terms of proposed land use and trips generated;
- b) a brief description of the existing operational conditions of the road network in the immediate vicinity of the development;
- c) analysis of the operation of the accesses and parking arrangements for the development;
- d) analysis of the parking demand and supply of the development;
- e) analysis for the mobility impaired;
- f) analysis of the operation of the first intersection, as a minimum, on either side of the accesses;
- g) a conceptual geometric layout of the access arrangements, including any nearby driveways and intersections; and
- h) professional opinion on the expected traffic impact based on a site observation during the expected critical peak hour and the analysis conducted.

4. Traffic Impact Study

A *Traffic Impact Study* should follow the standard format and structure described in the Roads and Maritime Authority's (RMS) '*Guide to Traffic Generating Developments*' (as amended from time to time by a superseding document prepared by RMS).

Adopted: DRAFT

Effective: DRAFT

All proposed developments listed in Schedule 3 of State Environmental Planning Policy (Infrastructure) 2007 require referral to either a Regional Traffic Development Committee or a Local Traffic Development Committee. In most situations, a *Traffic Impact Study* will be required for developments listed under column 2 in that schedule.

5. Road Safety Audit

The person carrying out the traffic impact assessment will need to determine whether a Road Safety Audit, prepared in accordance with RMS requirements, needs to be included as part of the traffic impact assessment. This would be particularly relevant when road safety is identified as a major concern, for example, activities that generate large numbers of heavy vehicles or new schools.

Road safety audits must consider the access and safety of all road users, modes of transport and services delivered within the road reserve such as bus stops and waste collection.

B4.2.2 Parking Layout Standards

1. Car parking requirements, parking layout, driveway widths and vehicle manoeuvring areas are to be in accordance with the relevant sections of the current editions of Australian Standard 2890.
2. All parking spaces in commercial and industrial developments must be available for unrestricted public access and employee use. There shall be no restriction on public parking in the required car park, other than car spaces set aside for any residential units approved on the site.
3. Access for the disabled and parking facilities are to be provided in accordance with the current editions of AS 2890 and the Building Code of Australia and the requirements of the *Disability Discrimination Act, 1992* (Commonwealth).
4. Tandem or stacked parking is not generally favoured. However, in certain cases, the provision of a limited number of employee parking spaces may be provided in this way in circumstances where no inconvenience arises from its use and subject to the following guidelines:
 - a) The applicant must be able to demonstrate that there is a real need for stacked parking and that the provision of stacked parking will not adversely affect the use of the site.
 - b) No more than two (2) cars are parked in a stacked arrangement, so that no more than one (1) vehicle has to move to allow egress of another.
 - c) Stacked parking is only to be used to provide parking for people employed on the premises and likely to park all day or a major part of the day.
 - d) Stacked parking spaces are to be used by the occupants of the site in one tenancy.
 - e) Stacked parking for customer/public and for separate **dwelling**s on the same property will not be supported.

B4.2.3 Vehicle Access and Manoeuvring Areas

1. Driveways and manoeuvring areas are to be designed and constructed in accordance with the requirements of the current editions of Australian Standard 2890, Austroads and the Northern Rivers Local Government Development & Design Manual.
2. All parking and service areas shall be provided with sufficient manoeuvring areas to allow vehicles to enter and leave the site in a forward direction. **Dwelling houses** and **dual occupancy developments** may seek a variation this requirement on roads with low traffic volumes by demonstrating there are no traffic safety issues on the frontage roadway or within the site.
3. Designs for manoeuvring areas are to be in accordance with the current editions of Australian Standard 2890 and must include a swept path analysis for the relevant design vehicle.
4. Driveways, manoeuvring areas and parking areas, including loading & unloading areas, should be sealed with an all weather surface, such as asphalt, bitumen seal, concrete, pavers or other similar treatment. Porous paving should be provided, where soils are capable of high infiltration rates, for parking spaces (other than those for people with disabilities) and domestic driveways. Gravel surfaces are generally not acceptable in urban locations and some rural situations (issues such as noise, dust, and erosion need to be considered).
5. Internal driveways for more than three **dwelling**s should have a minimum driveway width of 5.5 metres to facilitate two way access. The driveway width may be reduced to a minimum width of 3.5m where there are no potential internal driveway conflicts or traffic safety issues having regard to the following:
 - a) a minimum driveway width of 5.5m is provided for at least the first 6 m from the property boundary;
 - b) adequate passing opportunities are provided;
 - c) good sight distance is available;
 - d) slope of driveway is not excessive;
 - e) frontage roadway has less than 3000 vehicle trips per day; and
 - f) traffic and pedestrian volumes on the driveway.
6. Where driveways are to be negotiated by a waste collection vehicle, they must have a maximum gradient of 16% at any one point.
7. Internal driveways for three dwellings or less are to have a minimum width of 3m with a 4m wide X 2.7m high access corridor to facilitate landscaping, services, retaining walls etc.
8. Driveways for hatchet shaped lots should be fenced and landscaped on either side in order to minimise any potential noise or light pollution for adjoining lots with different ownership.
9. The design of access to a development from a high speed (> 50km/hr) or high volume road (> 3000 vehicles per day), should not allow hazardous diverging or merging manoeuvres to occur on the through traffic lanes. The construction of turn lanes for vehicle movement for

proposed developments are to be provided on major roads where the conflict between the turning traffic and any opposing major road traffic, may cause a substantial traffic delay or risk. Development applications must be supported with turn warrant assessments and preliminary engineering plans of the necessary treatment/s - refer to Austroads publications.

B4.2.4 Structures Adjacent to Driveways

Boundary fencing, garages, carports, landscaping, vegetation, signs, letterboxes or any other structures adjacent to a driveway that exceed 1.15 metres in height are to demonstrate compliance with the current editions of Australian Standard 2890 in relation to the provision of sight lines for vehicles and pedestrians. No permanent sight obstruction exceeding 1.15 metre in height shall be located within the identified clearance area for sight distances. The following diagram is provided from Australian Standard 2890.1:2004 for guidance:

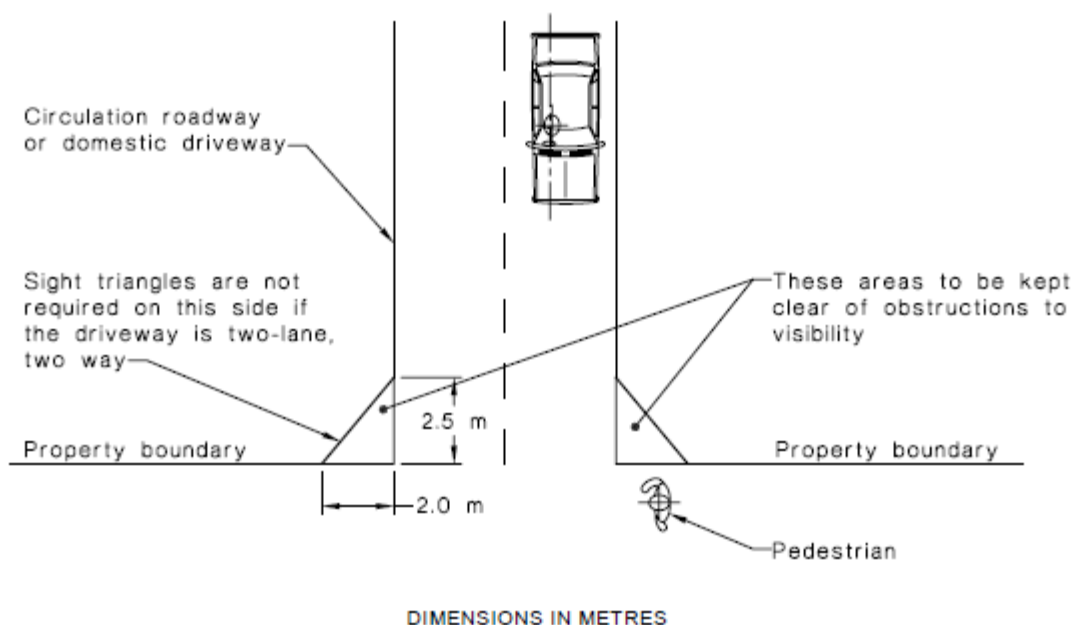

Figure B4.1 – Minimum Sight Lines for Pedestrian Safety (Source: Australian Standard 2890.1:2004)

B4.2.5 Car Parking Requirements

1. Unless otherwise specified elsewhere in this DCP, car parking is to be provided in accordance with the schedule contained in Table B4.1
2. Where a proposed use is not represented in Table B4.1 or elsewhere in this DCP, the rates under the RMS Guide to Traffic Generating Developments (as amended from time to time by a superseding document prepared by RMS) will apply.
3. If a rate is not provided by the RMS Guide to Traffic Generating Developments (as amended from time to time by a superseding document prepared by RMS) a merit based assessment will apply. In such circumstances applicants are encouraged to review car parking rates for adjoining or surrounding Councils and to contact Council's Development Engineers as to what an appropriate rate may be.

B4.2.6 Underground/ Basement Car Parks

1. Where excavation is proposed for basement **car parks** development applications should demonstrate that:
 - a) The proposed access to and appearance of the **car park** will be visually compatible with the existing and desired future character of the locality, streetscape and immediate surrounds.
 - b) The proposed access to the **car park** is consistent with the Council's pedestrian and traffic management strategies for the commercial area and will not detract from pedestrian safety or the safety and amenity of community spaces or any public road. In this regard rear lane or secondary street access to the basement **car park** is preferred to minimise amenity impacts to streetscape and remove pedestrian conflicts.
 - c) All **earthworks** are located on the subject property and do not require any underpinning into neighbouring properties or adjoining road reserves.
 - d) Access to the basement complies with the **Flood Planning Level** to prevent the ingress of flood waters. Where grading cannot achieve compliance with the **Flood Planning Level** and provided no other feasible option (i.e. driveway design) is available, then the design may incorporate elements (e.g. ramps etc) or automatic mechanisms (e.g. hydraulic barriers etc) to prevent the ingress of flood waters to the basement, subject to the elements or mechanisms complying with the relevant **Flood Planning Level**. The basement to also include facilities for the pumping of water in the event of failure, or larger flood events.
 - e) Access to the basement is designed to prevent the entry of stormwater. Driveway ramps that allow for the ingress of rainwater are to be predominantly covered, with a maximum area of 60m² only that is exposed to direct rainfall.
 - f) The proposal will not adversely affect **groundwater** levels, flows, characteristics or quality.

B4.2.7 Car Parking Credits and Street Parking

1. Council may acknowledge car parking credits for a site based on the current approved use/s.
2. Any car parking credit shall be based on the rates in Table B4.1 in this DCP Chapter.
3. Car parking credit is equivalent to the parking requirement for current approved use/s calculated in accordance with (1) and (2) above, less the number of parking spaces specified by current approvals.
4. Where a developer contribution for car parking has previously been paid for a current approved use/s on a development site, new development may be entitled to car parking credits equivalent to the number of spaces for which developer contributions were received by Council if the above calculation does not acknowledge the credit.
5. Where a car parking credit has previously been granted for land dedications in conjunction with development, a new development on the same site will be entitled to take that into consideration in calculating the number of car parking credits.

Adopted: DRAFT

Effective: DRAFT

6. Car parking credits are not transferable to other development sites.
7. Council will consider proposals to increase on street parking capacity for the provision of some or all customer car parking spaces by increasing on street parking capacity where there is a material public benefit, and where:
 - a) The net increase in formalised (ie paved &/or linemarked) on street parking is 25% greater than the number otherwise required on site;
 - b) The resulting streetscape conforms with the principles of good urban design;
 - c) The level of pedestrian, cycle and traffic amenity on the street is maintained; and
 - d) The proposal is not detrimental to utility services.

Note: Council is more likely to give favourable consideration to such proposals if they provide an offsetting benefit to the public - such as property boundary setback dedication to allow conversion of existing parallel parking to angle parking. Other proposals that promote ESD policies will also be entertained.

In B4.2.7, 'current approved use' means a current use for which there is an effective development consent in place or an existing lawful use.

B4.2.8 Bicycle, Motorcycles and Coach Parking

1. Bicycle Parking

Development Proposals must make provision for bicycle parking in accordance with Table B4.1. The Bicycle parking is also to be designed in accordance with the current editions of AS 2890 Parking Facilities, Austroads and the NSW RTA Bicycle Guideline 2005 as appropriate and as nominated under Chapter B5 Providing for Cycling.

2. Coach Parking

Large developments, such as shopping centres, sporting facilities and hotels require on-site parking for regular passenger buses (and taxis), shopper-coaches, tourist coaches, etc. Parking for sufficient numbers of vehicles at convenient places (usually at main entrance points) should be provided on-site. Adequate provision must be made for access, safe manoeuvring and parking of coaches in proposals for tourist, commercial and recreational developments. Where applicants submit alternate proposals for a lesser number of car parking spaces based on bus/ coach transport, then bus parking will be required on the site.

A reduction in car parking may be approved if adequate demonstrated arrangements are made for bus/coach or other transport to the development. Any reduction shall be validated by a Traffic Impact Study & Survey.

3. Motorcycles

To encourage alternative forms of motor transport and to enable applicants to utilise areas within a car park that are undersized for the standard vehicle space, the following motorcycle parking provisions are to apply:

Adopted: DRAFT

Effective: DRAFT

- a) Large commercial developments with a gross floor area exceeding 1000m² shall make provision for the parking of motorcycles. Two percent of car parking spaces shall be converted to Motorcycle spaces at a general rate of 4 motor cycle spaces for every space converted. (e.g. a development generating 50 car parking spaces will have 49 car parking spaces and 4 motorcycle spaces).
- b) For smaller developments where motorcycle spaces are proposed in lieu of car parking, these will be considered on merit, provided a minimum of 90% of parking is for cars, and 4 bike spaces are provided for every vehicle space not provided (eg a development generating 10 car parking spaces, could propose 9 spaces and 4 motorcycle spaces).

B4.2.9 Loading Bays

1. All developments have a need for a safe loading and unloading area (service area) which does not obstruct the passage of vehicles or pedestrians. Unless designed specifically for a nominated vehicle type or types appropriate to the use of the proposed development, loading bays should be provided in accordance with the schedule contained in Table B4.2.
2. Where a proposed use is not represented in Table B4.2, the rates under the RMS Guide to Traffic Generating Developments (as amended from time to time by a superseding document prepared by RMS) will apply.
3. Access, loading bays and manoeuvring for a service area must be designed in accordance with the current editions of AS 2890 Parking Facilities.
4. In general, service areas should satisfy the following requirements:
 - a) The service area must be a physically defined location, screened from public view, and not used for purposes other than servicing, loading and unloading.
 - b) Service area layout must facilitate its efficient use and must effectively discourage on-street loading and unloading.
 - c) Requirements for storage and collection of waste must be taken into account in service area design.
 - d) All service vehicles must be able to enter and leave the site in a forward direction, i.e. adequate manoeuvring space is required on site.
 - e) Internal roadways must be of a size adequate for the largest vehicle anticipated to use the site.
 - f) Service vehicle movements should be separated from car movements.

B4.2.10 Monetary Contributions

Council may consider accepting a monetary contribution in lieu of on-site car parking on land predominantly zoned B2 where there is a nexus between the development and the area in which public parking is or will be provided. Such cases will be considered on merit, with reference to:

- a) the size of the development;

Adopted: DRAFT

Effective: DRAFT

- b) the site's proximity to, and the accessibility of, existing or proposed public car parking areas;
- c) the demand for car parking generally in the locality; and
- d) the general traffic flow in the area;
- e) the cost to Council of providing the parking off site;
- f) the likelihood of the parking being occupied and not being available for parking associated with the proposed development.

Should a monetary contribution be proposed, applicants will need to discuss this option with Council prior to lodgement of the Development Application, and propose either a voluntary planning agreement (VPA) or submit a VPA with the development application. (Note: There is no Section 94 Plan for car parking).

In locations away from the main commercial areas, or where no public **car parks** are planned, on-site car parking is to be provided with the development.

For works in kind, Council may consider car parking on public land or in the road reserve for all or part of the car parking required for an adjacent development proposal. Such work if permitted, is at the applicants expense, and such arrangements will only be allowed when a positive outcome results and the streetscape is improved.

B4.2.11 Landscaping

As an integral and important component of outdoor parking area design, suitable landscaping must be provided in accordance with the requirements of Chapter B9 Landscaping. In particular shade trees can assist with cooling the car parking area and the vehicles parked therein, and assist with managing the microclimate of urban areas.

Specifically outdoor **car parks** comprising 10 or more vehicle spaces are to incorporate a landscape bay of a suitable dimension to support the healthy growth of shade trees with a minimum height of 8 metres (at maturity) to shade every 2-5 parking spaces. The bay can also incorporate **water sensitive urban design** principles to facilitate stormwater disposal and also irrigation of the trees. Figure B4.1 below illustrates various **car park** landscaping configurations.

Adopted: DRAFT

Effective: DRAFT

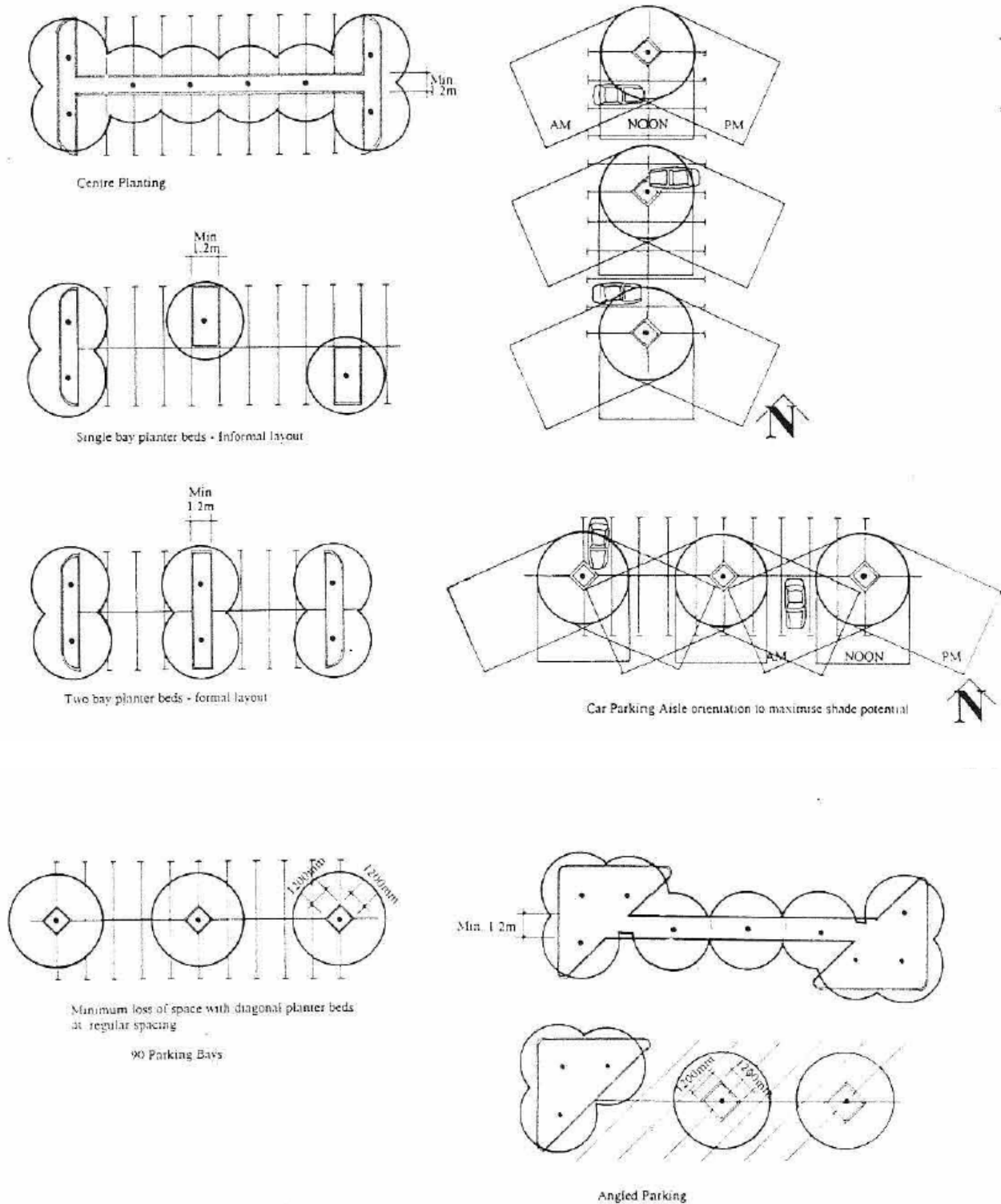

Figure B4.2 – Car park landscaping configurations (Source: South Sydney DCP No. 11 Transport Guidelines for Development 1996)

B4.2.12 Parking Schedules

Table B4.1 – Parking Rates

Land Use	Car Parking	Bicycle Spaces
Amusement centre	4 spaces per 100m ² GFA plus 1 per 2 employees	8 per 100m ² of GFA
Artisan food and drink industry	0.4 space per patron or 1 space per 40m ² GFA, whichever is the greater	1 per 25m ² of GFA
Backpackers accommodation	1 space per 8 beds	1 per 5 beds
Bed and breakfast accommodation	1 space per guest bedroom plus 1 space per dwelling	
Boarding house	See SEPP (Affordable Rental Housing) 2009	1 space per bed
Business premises	1 space per 20m ² GFA	2 per 100m ² (or part thereof) up to a floor area of 200 m ² and 1 per 200 m ² thereafter
Bulky goods premises	1 space per 50m ² GFA	
Caravan park/ Camping grounds	In accordance with the <i>Local Government (Manufactured Home Estates, Caravan Parks, Camping Grounds and Moveable Dwellings) Regulation 2000</i>	
Caretaker dwelling	See medium density housing, except visitor car spaces are not required.	

Adopted: DRAFT

Effective: DRAFT

Land Use	Car Parking	Bicycle Spaces
Commercial premises	See business premises	
Community facilities	Merit based at a general rate of 1 space per 40m ² of GFA.	1 per 100 m ² of GFA
Child care centre	1 space per 4 children plus drop off/pick up area	
Dual occupancy	See medium density housing , except visitor car spaces are not required where on-street car parking is available within close proximity to the development.	
Dwelling house	2 spaces per dwelling	
Educational establishment	(Primary) 1 space per 2 staff members	1 per 5 students over year 4
Educational establishment	(Secondary) 1 space per 2 staff members plus 1 per 10 students aged 17 and over	1 per 5 students
Educational establishment	(Tertiary) 1 space per 5 students plus 1 space per 2 staff members	1 per 5 students
Entertainment facility	1 per 10 seats	1 Space per 10 car parks
Exhibition home	2 spaces per home external to garage/ dwelling parking Space	
Food and Drink Premises	1 per 20 m ² of GFA in Business and Industrial	1 per 25m ² of GFA

Adopted: DRAFT

Effective: DRAFT

Land Use	Car Parking	Bicycle Spaces
	Zones. 1 per 7.5 m ² in all other zones.	
Function centre	Same as food and drink premises	
Funeral home	2 spaces plus either 1 space per 30m ² GFA or 1 per 5 seats in chapel, whichever is greater	
Garden centre	1 space per 70m ² display area (including accessories). Where landscape supplies are included an additional 1 space per employee plus 2 customer spaces.	
Group home	Refer <i>SEPP (Affordable Rental Housing) 2009</i>	
Hardware and building supplies	1 space for 50m ² GFA.	
Health consulting rooms	2 spaces per consulting room plus 1 space per 2 employees plus any dwelling requirement	1 space per consulting room
Hotel or motel accommodation	1 spaces per unit plus 1 space per 2 employees (on site at any one time) plus 1 space for on-site manager. If public restaurant or function room included, as per food and drink premises	2 Spaces for accommodation units only If public restaurant or function room included, add 1 per 25m ² of GFA
Industry	1 space per 100 m ² or two per factory unit which ever is the	

Adopted: DRAFT

Effective: DRAFT

Land Use	Car Parking	Bicycle Spaces
	greater.	
Kiosk	See food and drink premises	See food and drink premises
Landscape material supplies	1 space per employee plus 2 customer spaces Where applicable add 1 space per 70m ² product display/showroom area	
Market	2.5 spaces per stall	1 space per 10 stalls
Medical centre	1 space per 20m ² GFA plus any ancillary development requirement	1 space per consulting room
Mortuary	See funeral home	
Medium density housing including multi dwelling housing, residential flat buildings and shop top housing	1 space per 1 or 2 bed unit, 2 spaces per 3 or more bed unit, 1 visitor space per 4 dwellings or part thereof. Each dwelling to have at least one covered car space. Where dwellings are designed with studies/ offices and other areas capable of being utilised as separate sleeping quarters these will be counted as bedrooms.	
Neighbourhood shop	See retail premises	
Office premises	See business premises	See business premises
Place of public worship	1 space per 10 seats	1 space per 100 seats

Adopted: DRAFT

Effective: DRAFT

Land Use	Car Parking	Bicycle Spaces
<i>Plant nursery</i>	See <i>garden centre</i>	
<i>Pub</i>	1 space per 5m ² of public area in bars and lounges.	2 per 25 m ² of public areas in bars and 2 per 100 m ² of lounges and beer gardens
<i>Public administration building</i>	See <i>business premises</i>	
<i>Recreation facility (indoor)</i>	Bowling Alley: 3 spaces per lane Squash Courts: 3 spaces per court Gymnasium: 1 spaces per 20m ² GFA Other activities: on merit	1 per 4 employees and 1 per 200m ² of GFA
<i>Recreation facility (outdoor)</i>	Tennis Courts: 3 spaces per court Bowling Club: 15 spaces per green plus any restaurant and pub requirements where applicable Golf Course: 4 spaces per hole on course plus any food and drink requirements where applicable. Other activities: on merit	1 per 4 employees and 1 per 200m ² of GFA
<i>Registered club</i>	See <i>pub</i>	See <i>pub</i>
<i>Restaurant</i>	See <i>food and drink premises</i>	See <i>food and drink premises</i>
<i>Retail premises</i>	See <i>business premises</i>	See <i>business premises</i>

Adopted: DRAFT

Effective: DRAFT

Land Use	Car Parking	Bicycle Spaces
Roadside stall	Assessed on merit Consideration to be given to parking rates for markets	
Rural supplies	1 space per 50m ² GFA	
Rural tourist accommodation	1 space per guest bedroom	
Secondary dwelling	Nil	
Seniors housing	See <i>SEPP (Housing for seniors or people with a disability) 2004</i>	
Service station	5 spaces per mechanical Work bay plus 1 space per 20m ² of GFA of convenience store GFA. Tandem Parking permitted and work bays can be counted as a space.	
Serviced apartment	See medium density housing	
Shop	See business premises	See business premises
Shopping centre	Per area of gross leasable floor area (GLFA): 1000 -10,000m ² GLFA - 6.1 spaces per 100m ² 10,000 - 20,000m ² GLFA - 5.6 spaces per 100m ² > 20,000 m ² GLFA Parking Study required	See business premises

Adopted: DRAFT

Effective: DRAFT

Land Use	Car Parking	Bicycle Spaces
Small Bars	See Pub	See Pub
Shop top housing	See Medium density housing requirement plus shop requirement	
Takeaway food or drink premises	See food and drink premises	See food and drink premises
Timber yard	See landscape material supplies	
Transport Depot	1 space per vehicle driver, 1 per 2 onsite employee	
Truck Depot	1 space per vehicle driver, 1 per 2 onsite employee	
Vehicle repair station	5 spaces per service bay. Tandem parking permitted and service bays are counted as a car parking space	
Vehicle sales or hire premises	1 space per 200 m ² of GFA and any outdoor motor display, plus 5 per mechanical work bay. Tandem parking permitted and service bays are counted as a car parking space	
Veterinary hospital	3 spaces per veterinarian plus 1 space per 2 employees	
Warehouse or distribution centre	1 space per 300 m ² of GFA	
Wharf or boating facilities	1 per mooring	

Adopted: DRAFT

Effective: DRAFT

Land Use	Car Parking	Bicycle Spaces
	1 spaces per two employees	
<i>Wholesale supplies</i>	See <i>bulky goods premises</i>	

Table B4.2 – Loading Bays

Development type	Gross floor area (GFA), m ²	Number of Loading Bays Required by Vehicle Class			
		Small rigid vehicle	Medium rigid vehicle	Heavy rigid vehicle	Articulated vehicle
Business premises/office premises (For premises less than 200 m ² , loading bays can be shared with staff parking provided the parking bay meets the minimum dimension requirements under AS2890 for a small rigid vehicle, there is adequate manoeuvring area and the space is suitably located for loading and unloading on-site)	0-999	1	-	-	-
	1,000-2,499	-	1	-	-
	2,500-7,999	1	1	-	-
	8,000-19,999	2	1	-	-
	20,000-34,999	2	2	-	-
	35,000-64,999	2	2	1	-
>65,000	2	3	1	-	
Retail premises, tourist and visitor accommodation (except bed and breakfast accommodation and	0-199	1	-	-	-
	200-599	-	1	-	-
	600-1,499	1	1	-	-

Adopted: DRAFT

Effective: DRAFT

Development type	Gross floor area (GFA), m ²	Number of Loading Bays Required by Vehicle Class			
		Small rigid vehicle	Medium rigid vehicle	Heavy rigid vehicle	Articulated vehicle
farmstay accommodation) (For premises less than 200 m ² , loading bays can be shared with staff parking provided the parking bay meets the minimum dimension requirements under AS2890 for a small rigid vehicle, there is adequate manoeuvring area and the space is suitably located for loading and unloading on-site)	1,500-1,999	2	1	-	-
	2,000-2,799	2	2	-	-
	2,800-4,399	2	2	1	-
	4,400-8,499	2	2	1	1
	8,500-11,499	3	2	1	1
	11,500-20,999	3	3	1	1
	21,000-23,999	3	3	2	1
	24,000-32,999	3	3	2	2
	>33,000	3	4	3	2
Industry (For premises less than 200 m ² , loading bays can be shared with staff parking provided the parking bay meets the minimum dimension requirements under AS2890 for a medium rigid vehicle, there is adequate manoeuvring area and the space is suitably	0-199		1	-	-
	200-799		-	1	-
	800-1,599		1	1	-
	1,600-2,399	1	1	1	-
	2,400-3,199	1	1	1	1

Adopted: DRAFT

Effective: DRAFT

Development type	Gross floor area (GFA), m ²	Number of Loading Bays Required by Vehicle Class			
		Small rigid vehicle	Medium rigid vehicle	Heavy rigid vehicle	Articulated vehicle
located for loading and unloading on-site)	3,200-3,999	1	2	1	1
	4,000-4,799	2	2	1	1
	4,800-5,599	2	3	1	1
	5,600-6,399	2	3	2	1
	6,400-7,199	2	3	3	1
	7,200-7,999	2	3	3	2
	>8,000	Same as previous – additional loading bays to be assessed on merit at a general rate of 1 bay per 1000m ² GFA			